

PYRO CLASSIC

HOTFLOW WETBACK INSTRUCTIONS

THIS DOCUMENT MUST BE READ BY PLUMBER

PLEASE NOTE: HOTFLOW INDUSTRIES AND ANY OF THEIR PERSONNEL WILL NOT CARRY ANY LIABILITY FOR DAMAGE CAUSED THROUGH:

- **INCORRECT INSTALLATION** - Care should be taken to see that no air traps can exist in both the **HOTFLOW** unit or the circuitry ALL CIRCUIT DROPS MUST BE VENTED
- **INSTALLATIONS IN UNACCEPTABLE OR CORROSIVE WATER (e.g. LIME – IRON – etc.).** Care must be taken to protect the **HOTFLOW** wetback element and associated pipework if being installed in a hard/corrosive water area. Damage caused to the wetback element if fitted in a hard/corrosive water area will not be covered under the manufacturer's warranty.
- **DAMAGE CAUSED THROUGH MALTREATMENT OF THE UNIT**

Care **MUST** be taken during installation.

DO NOT OVERTIGHTEN BRASS BACKNUTS - expansion/contraction could split the thread if it's too tight, creating a leak.

Only the correct size threaded nut type fittings must be used when attaching this wetback to the water pipes, the use of any form of soldering or brazing to connect

FITTING THE WETBACK

1. Ensure equal lengths of brass socket are extended out through back wall.
2. Ensure there is no Kaowool/insulation blanket caught between back nut and the inside wall of fire.
3. Hand tighten outer nuts to firm touch of plate, then 1/4 turn (approx 15 to 20 Ft Lbs) is all that's required.
4. Check for rise across the entire element.

DAMAGE CAN BE CAUSED THROUGH THE ABSENCE OF WATER IN THE UNIT DURING FIRE OPERATION

(Water must be in the unit prior to any fire-lighting. Failure to do this will lead to irreparable damage / potential explosion)

The design of this unit is protected and any unauthorized manufacture of this unit or its

TECHNICAL AND INSTALLATION INFORMATION FOR WATER HEATING ELEMENT

The **HOTFLOW WATER HEATING ELEMENT** (wetback) is designed to heat water to save electric power costs and to provide a more efficient heating source than current boosters that are fitted to most solid fuel heating appliances at present.

The **HOTFLOW WATER HEATING ELEMENT** (wetback) is normally installed by plumbers, and other such qualified installers who would have a knowledge of alternative water heating systems such as wetbacks.

The **HOTFLOW WATER HEATING ELEMENT** (wetback) has undergone lengthy performance trials, and performance data is available of these tests.

The **HOTFLOW WATER HEATING ELEMENT** (wetback) is more efficient because of:

- A. ITS DESIGN – A system of copper tubes linking riser and header tanks formed in such a way as to minimise water coring.
- B. INSTALLATION SITE – It is installed in the direct heat of the fire.
- C. RETURN RESISTANCE – An integral part of the design is the calculated resistance built in to encourage the forward momentum of heated water – (HYDROSURGE) thereby overcoming distance problems.

The ABC of this unit all acts together as an integrated design that assures a very effective performance providing installation and use is in accordance with the manufacturer's guidelines.

The **HOTFLOW WATER HEATING ELEMENT** (wetback) has 20mm brass connecting thread – in the tradition of older wetbacks – and these act both as circuit connectors, and fire mounts.

The **HOTFLOW WATER HEATING ELEMENT** (wetback) can operate through either 20mm or 25mm copper

circuitry – all trial results have been achieved through 20mm circuitry, however in the case of retrofitting to existing circuitry either diameter or a combination of both is acceptable.

The HOTFLOW WATER HEATING ELEMENT (wetback) is designed for open vented – low pressure circuits – as is the legal requirement for all such uncontrolled water heating alternatives.

The HOTFLOW WATER HEATING ELEMENT (wetback) – in all tests to date, generates around 30 ltrs of hot water into the cylinder per hour, depending on fire conditions.

GENERAL COMMENTS

CIRCUITRY MATTERS:

1. Circuitry can be 20mm or 25mm copper tube (N.Z.S.4063:501.1).
2. The design of the unit under correct installation generates sufficient volume to fulfill the criteria of pumping action and creates a flowrate performance to satisfy NZBC, G.12.3.5(b).
3. All Hotflow line circuitry must rise - and all dropped circuitry must be vented.
4. Attention should be paid to see that COLD feed line does NOT have any air traps. This line is often neglected. It should have fall either way so as to encourage the release of any trapped air and should be checked for flow rate particularly in old circuits.
5. Circuit profile should be as recommended NZBC 4603 Fig 5 CORRECT WETBACK ARRANGEMENTS

CIRCUIT OPTIONS – The modern event of concrete floored dwellings creates the option of TWO OVER THE TOP because the option of UNDER and OVER is cancelled out.

In the case of TWO OVER THE TOP both the HOT and COLD FLOW lines can follow each other over the top and drop again enroute to and from the cylinder. This will work fine provided the rules of venting are applied to the COLD line as well as the HOT line.

NOTE: IT IS TOTALLY UNACCEPTABLE TO RUN THE HOT CIRCULATING FLOW LINE DIRECTLY UNDER THE FLOOR FROM THE FIRE. DUE CARE AND

ATTENTION MUST ALWAYS BE PAID TO VENTING AND UNDERSTANDING RESISTANCE. INCORRECT VENTING CAN LEAD TO PRESSURE BUILD UP, SPLIT CIRCUITRY AND/OR NOISEY INSTALLATIONS.

PRESSURE BUILD UP IS DANGEROUS.

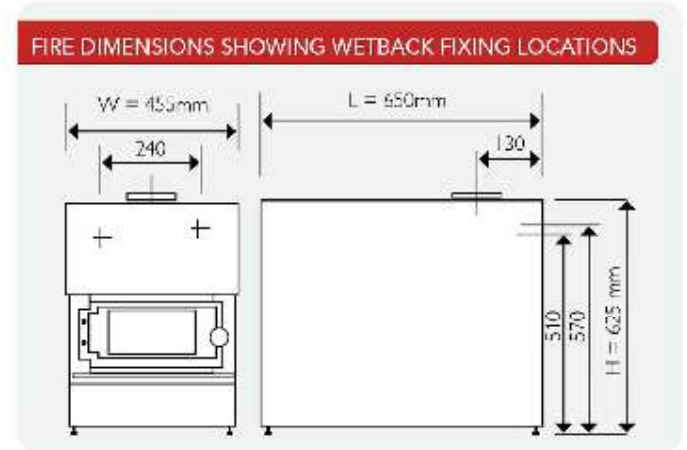

Disclaimer: +/- 2mm measurement variation.

HOTFLOW UNIT INSTALLATION GUIDE

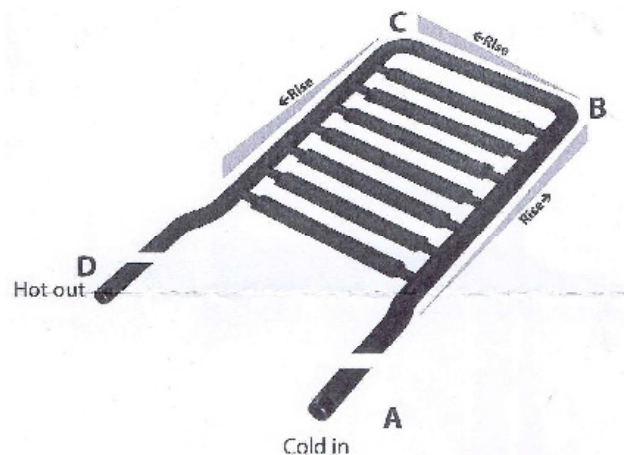

For correct venting, the Hotflow Unit **must** rise as shown above, once mounted.

B must be above A

C must be above A and B

D must be above A, B and C

A spirit level is required for correct installation



PYRO CLASSIC HOTFLOW HYDROSURGE WETBACK HEATING SYSTEM

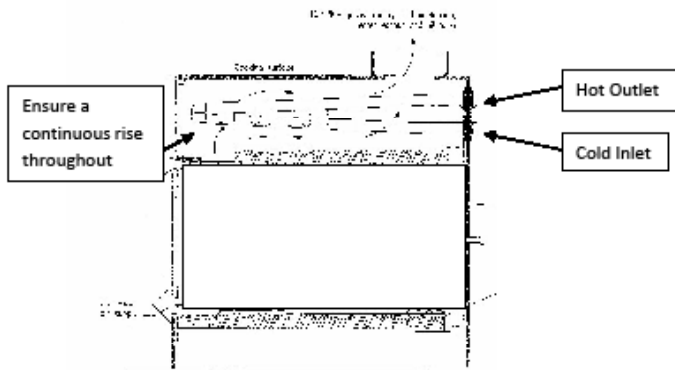

Pyro Classic side cut away showing Wetback in top chamber

The Hotflow Wetback is installed through the removal of the top plate of the fire, you do not need to remove any bolts other than the blanking washers in the back plate.

The Hotflow Wetback sits inside the secondary chamber of the Pyro Classic and fits into the Pyro Classic inlet and outlet ports on the back of the fire, it is imperative that the Hotflow wetback is positioned correctly for optimum operation. The Hotflow Wetback must rise from the cold inlet to the front and from the front rise back to the hot outlet as any departure from this could lead to inefficiencies and unwanted noise.

The profile of the Hotflow Wetback must be carefully set to ensure it is free of any likely air traps, this will allow the Hydrosurge principle to function correctly, once the constant rise of the unit has been set be sure to tighten up the mounting nuts on the treaded ends, taking note of the torque settings laid out on page 1.

The location of the Hotflow Wetback water heating element in the secondary chamber does not interfere with the very efficient clean burning primary chamber of the Pyro Classic, ensuring that it will continue to operate as cleanly and efficiently as its design allows.

HOTFLOW PERFORMANCE TEST RESULT

TRIAL CONDITIONS :

1. ENVIRONMENT – PARTLY OUTDOORS

2. CYLINDER TO FIRE CIRCUITRY
 - a. Length 20mtrs
 - b. Diameter 20mm
 - c. Description– KEMLAG approx 20% eff 120 ltr VARIOUS BELL ELECTRONICS PROBES PLACEMENTS CYLINDER ENTRY

3. CYLINDER CAPACITY

4. FIRE INSTALLATION

5. TEMPERATURE MONITORS

30ltr level – 60ltr level – 90ltr level – 120ltr level

6. AVERAGE TEST TIME EQUALS 4 HOURS READING

Average starting water temperature 9.5 dgC

Average 4 hour final reading cylinder temperature 60.0 dgC

Average water temp at cylinder entry 75/80 dgC

Average cylinder temp increase per hour 1 2.6 dg/hr

COMMENTARY: The above detail shows that under good average fire conditions the HOTFLOW WATER

HEATING ELEMENT can heat a domestic hot water cylinder without electricity support at a rate more than comparable with the standard electricity rate at a distance of 50 ft from the energy source.

The HOTFLOW WATER HEATING ELEMENT generated approximately 3.5 kW at the cylinder.

Comparisons made with side – rear mounted and coil type water heaters show clearly that the HOTFLOW WATER HEATING ELEMENTS ability to heat water – AND PLACE IT IN THE CYLINDER - to be far, far superior to any water heating (Wetback – booster) unit yet tested.

THE CLOSER THE DISTANCE = THE BETTER THE RESULTS

HOTFLOW LIMITED WARRANTY

COMPLIANCE:

- Hotflow industries stands by workmanship
- Production is by skilled engineers
- All units are pressure tested
- All materials comply to NZS
- The Hotflow unit complies with **NZS 4603 501.1 4603 402.a / b**

PLEASE NOTE:

Warranty is limited to manufacturers care and does not cover factors beyond their control. Hotflow stands by its workmanship and has a goodwill approach to problems brought to its attention prior to installation. All materials used are NZS approved and fit for purpose.

Hotflow Industries and any of the personnel will not carry any liability for damage caused through:

- **INCORRECT INSTALLATION** - Care should be taken to see that no air traps can exist in both the Hotflow unit or the circuitry (ALL CIRCUIT DROPS MUST BE VENTED).
- **INSTALLATIONS IN UNACCEPTABLE OR CORROSIVE WATER** (e.g. LIME – IRON – etc.)
Hotflow wetbacks should not be installed in a hard/corrosive water area. Damage caused to the wetback in this circumstance will not be covered.
- **INCORRECT SETTING OF THE UNIT IN THE FIRE:** The element must be installed as per the diagram provided. A spirit level must be used to determine its final position.
- **MALTREATMENT OF THE UNIT:** Due care must be taken during installation and maintenance. E.g. cleaning firebox OR chimney sweeping.
- **ABSENCE OF WATER IN THE UNIT DURING FIRE OPERATION:** Water must be in the unit prior to ANY fire lighting, failure to ensure will lead to irreparable damage.

IMPORTANT: WETBACK WARRANTY EXTENDS TO

INITIAL PLUMBING INTO SYSTEM AND FIRST PRESSURE TEST. FROM THIS MOMENT ON THE WARRANTY ENDS.

HOTFLOW MANUFACTURING WILL DETERMINE IF WARRANTY CLAIMS EXISTS - NOT THE INSTALLER.

COSTS ARE THE INSTALLERS OR CUSTOMER RESPONSIBILITY UNTIL WARRANTY HAS BEEN ESTABLISHED.

HOTFLOW INDUSTRIES

MIKIMIKI ROAD
RD8
MASTERTON

PH: (06) 372599

FAX: (06) 3725991